

Male Style C High Temperature

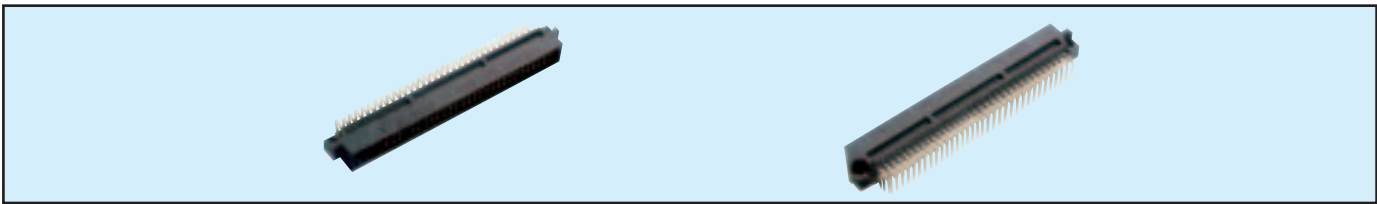

Series 8557 – 3 rows (3 x 32)



Contact Design and Termination Length	Number of Contacts	Loading Description	Part Number Performance classes according to DIN 41612	
			II	I
3.4 mm (Y) Straight	96	a + b + c fully loaded	10 8557 096 001 025	10 8557 096 001 049
	64	a + c fully loaded	10 8557 096 001 026	10 8557 096 001 050
	32	a + c even loading	10 8557 096 001 033	10 8557 096 001 057
	32	a loading only	10 8557 096 001 027	10 8557 096 001 051
3.0 mm (Y) Right Angled	96	a + b + c fully loaded	10 8557 096 002 025	10 8557 096 002 049
	64	a + c fully loaded	10 8557 096 002 026	10 8557 096 002 050
	32	a + c even loading	10 8557 096 002 033	10 8557 096 002 057
	32	a loading only	10 8557 096 002 027	10 8557 096 002 051
2.3 mm (Y) Right Angled	96	a + b + c fully loaded	10 8557 096 008 025	10 8557 096 008 049
	64	a + c fully loaded	10 8557 096 008 026	10 8557 096 008 050
	32	a + c even loading	10 8557 096 008 033	10 8557 096 008 057
	32	a loading only	10 8557 096 008 027	10 8557 096 008 051

NB: Alternative Prefix Variations Available: 16, please refer to Page 10.
Additional Plating & Loading Variations: Please contact your local AVX sales office or distributor.

LOADING DESCRIPTION

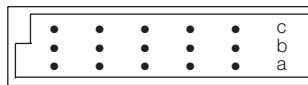

96 contacts, rows a + b + c fully loaded

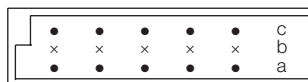

64 contacts, rows a + c fully loaded

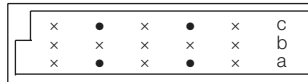

32 contacts, rows a + c even loading



32 contacts, row a loading only

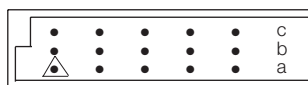

94 + 2 contacts, fully loaded with ground in A1 & A32

△ denotes ground pin

DIMENSIONS

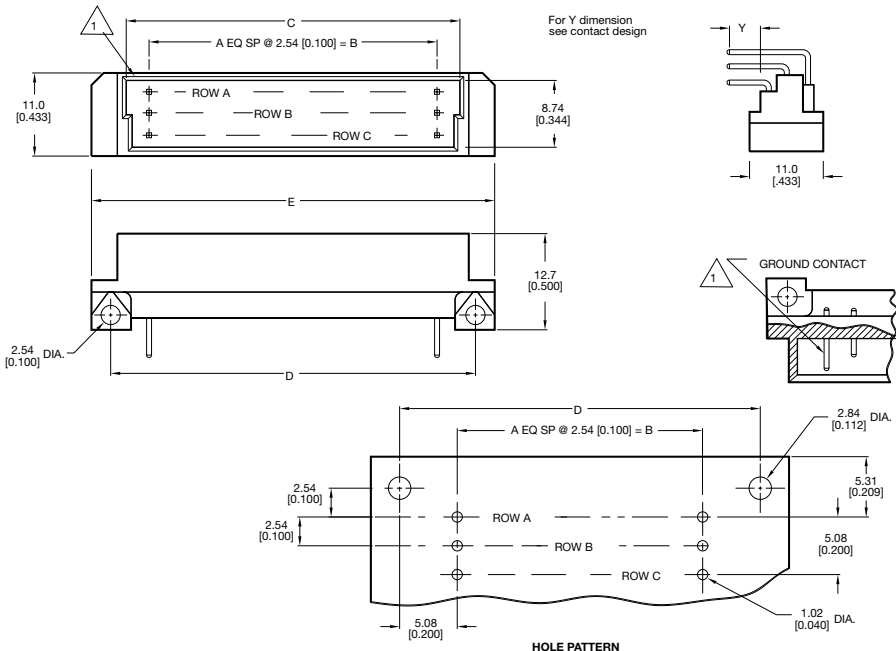

Unit: millimeters (inches)

No. Contact Positions	Contact Rows	A	B	C	D	E
96	3 (3 x 32)	31	78.74 (3.100)	85.29 (3.358)	88.90 (3.500)	93.90 (3.697)